

# AFM WORKSHOP™

This compact, tabletop Atomic Force Microscope has all the important features and benefits expected from a light lever AFM. The TT-AFM includes everything you need for AFM scanning: a stage, control electronics, probes, manuals, and a video microscope.

## TT-AFM

For:

▶ **Nanotechnology Researchers**

Wanting to do routine scanning of nano-structures.

▶ **Instrument Innovators**

Using AFM as a platform to create a new instrument.

▶ **Educators**

Teaching students about AFM construction, operation, and applications.

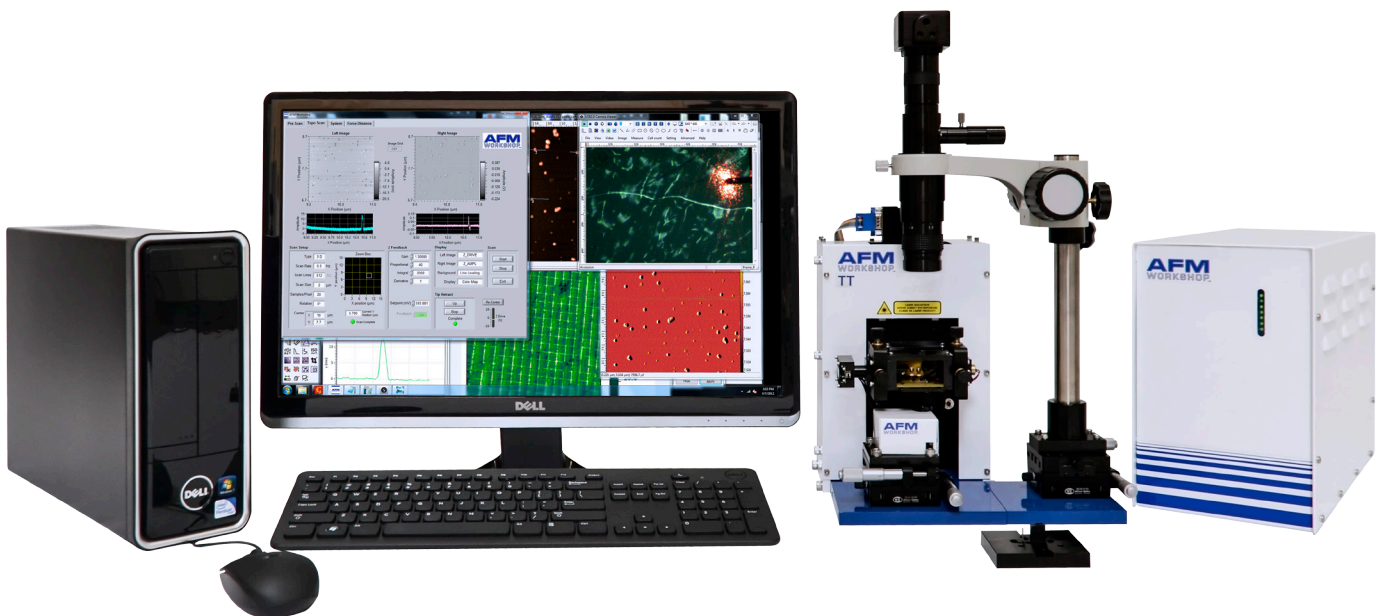

**Sample Sizes**

up to 1" X 1" X 1/4"

**Standard Scanning Modes**

Vibrating, Non Vibrating, Phase, LFM

**Scanners**

50 X 50 X 17 microns, 15 X 15 X 7 microns

**Video Optical Microscope**

Zoom to 400X, 1.5 micron resolution

**Stage and Ebox Size**

Compact Tabletop Design

# STAGE

The TT-AFM stage has excellent thermal and mechanical stability required for high resolution AFM scanning. Additionally, its open design facilitates user modification.

- ▶ **Rigid Frame Design**  
The crossed beam design for the stage support is extremely rigid so the AFM is less susceptible to external vibrations.
- ▶ **Light Lever AFM Force Sensor**  
Light lever force sensors are used in almost all atomic force microscopes and permit many types of experiments.
- ▶ **Integrated Probe Holder/Probe Exchanger**  
A unique probe holder and clipping mechanism allows quick and easy probe exchange.
- ▶ **Direct Drive Z stage**  
A linear motion stage is used to move the probe in a perpendicular motion to the sample. Probe/sample angle alignment is not required, facilitating a much faster probe approach.
- ▶ **Small Footprint**  
The stage dimensions of 7.5 X 12" require little space and fit easily on a tabletop.
- ▶ **Precision XY Stage with Micrometer**  
The sample is moved relative to the probe with a precision xy micrometer stage. Thus, the sample can be moved without touching it.
- ▶ **Modes Electric Plug**  
A six pole electrical plug is located at the back of the stage to expand the capabilities of the TT-AFM.
- ▶ **XYZ Precision Piezo Scanner**  
The modified tripod design utilizes temperature compensated strain gauges which assure accurate measurements from images. Also, with this design it is possible to rapidly zoom into a feature visualized in an image.
- ▶ **Laser/Detector Alignment**  
Both the light lever laser and the photo detector adjustment mechanism may be directly viewed. This feature simplifies the laser/detector alignment.
- ▶ **Adaptable Sample Holder**  
At the top of the XYZ scanner is a removable cap that holds the sample. The cap can be modified - or a new cap can be designed - to hold many types of samples.

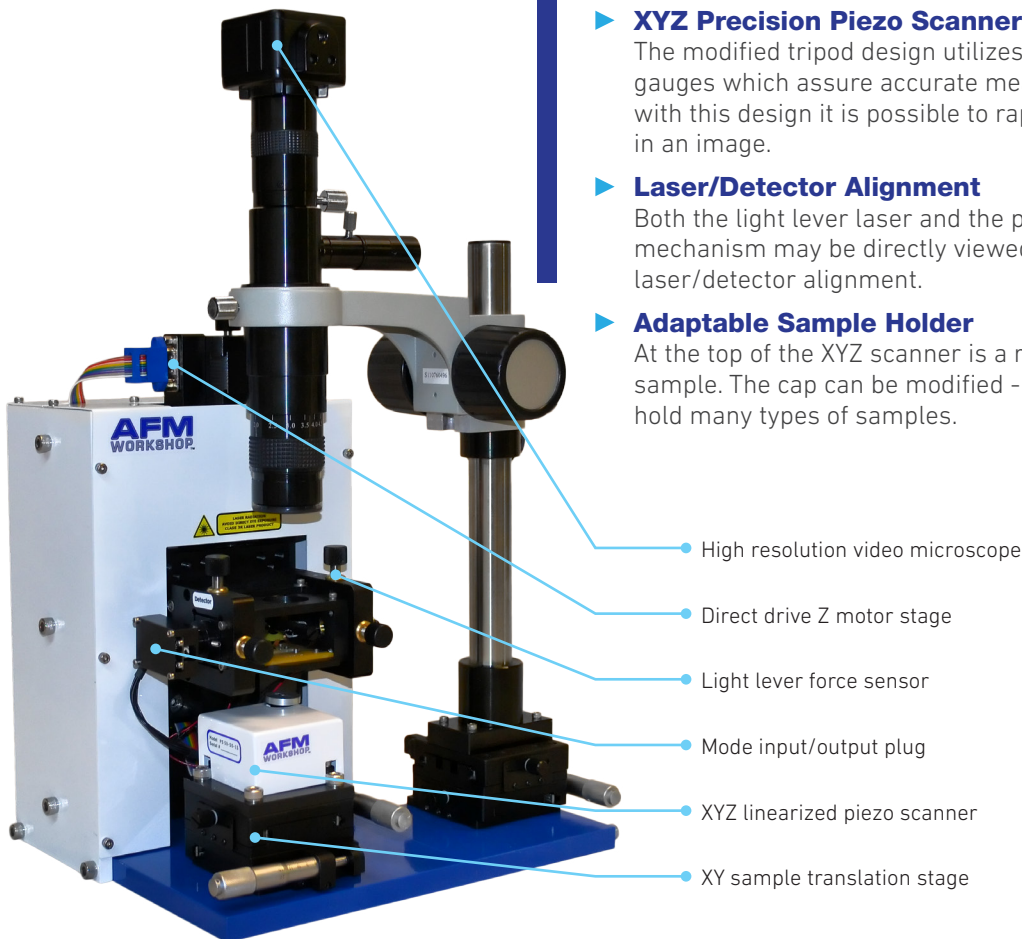

# EBOX

Electronics in the TT-AFM are constructed around industry standard USB data acquisition electronics. The critical functions, such as xy scanning, are optimized with a 24 bit digital to analog converter. With the analog z feedback loop, the highest fidelity scanning is possible. Vibrating mode scanning is possible with both phase and amplitude feedback using the high sensitivity phase detection electronics.

## ▶ 24 bit scan DAC

Scanning waveforms for generating precision motion in the X-Y axis with the piezo scanners are created with 24 bit DACS driven by a 32 bit micro controller. With 24 bit scanning, the highest resolution AFM images may be measured. Feedback control using the xy strain gauges assures accurate tracking of the probe over the surface.

## ▶ Phase and Amplitude Detector Circuit

Phase and amplitude in the Ebox are measured with highly stable phase and amplitude chips. The system can be configured to feed back on either phase or amplitude when scanning in vibrating mode.

## ▶ Signal Accessible

At the rear of the eBox is a 50 pin ribbon cable that gives access to all of the primary electronic signals without having to open the eBox.

## ▶ Status Lights

At the front of the Ebox is a light panel that has 7 lights. In the unlikely event of a circuit failure, these lights are used for determining the status of the Ebox power supplies.

## ▶ Precision Analog Feedback

Feedback from the light lever force sensor to the Z piezoceramic is made using a precision analog feedback circuit. The position of the probe may be fixed in the vertical direction with a sample-and-hold circuit.

## ▶ Variable Gain High Voltage Piezo Drivers

An improved signal to noise ratio, as well as extremely small scan ranges are possible with the variable gain high voltage piezo drivers.



Microprocessor for scan generation through 24 bit DAC's

Low noise, variable gain high voltage amplifiers with PID feedback for XY scanning

Dimensions: Width 6" | Height 10" | Depth 14"

High fidelity, low noise z feedback circuits for accurate probe tracking

Phase and amplitude detection circuits for vibrating mode AFM

Industry standard National Instruments USB data acquisition board

Internally accessible header for signal input/output

Eight channels of ADC for monitoring and displaying data with LabView software

# SOFTWARE

Software for acquiring images is designed with the industry standard LabVIEW™ programming visual interface instrument design environment. There are many standard functions, including setting scanning parameters, probe approach, frequency tuning, and displaying images in real time. LabVIEW™ facilitates rapid development for those users seeking to enhance the software with additional special features. LabVIEW also enables the TT-AFM to be readily combined with any other instrument using LabVIEW VI.

## ► Pre-scan Window

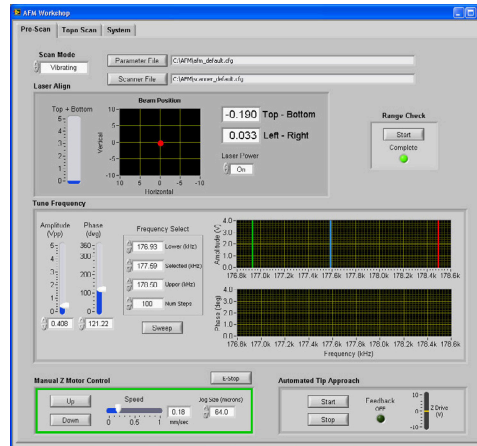

A pre-scan window includes all of the functions that are required before a scan is started. The functions are presented in a logical sequence on the screen.

## ► Scan Window

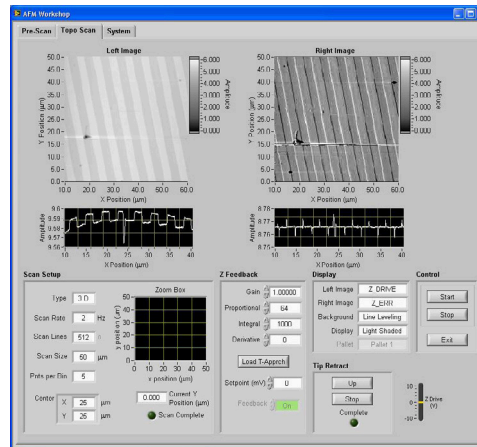

Once all of the steps in the pre-scan window are completed, the scan window is used for measuring images. Scan parameter, Z feedback parameters, and image view functions may be changed with dialogs on this screen.

## ► LabVIEW Window

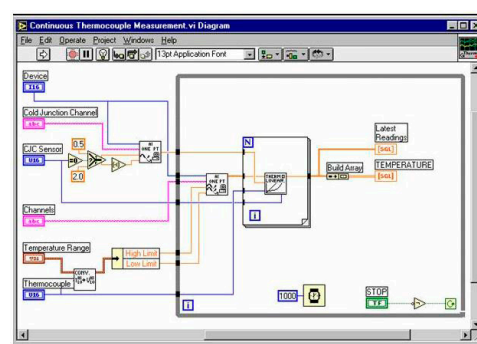

Industry standard programming environment. Readily customized and modified for specialized applications. Instrumentation already using LabVIEW can be added to the TT-AFM to create new capabilities.

# IMAGE ANALYSIS SOFTWARE

Included with the TT-AFM is the Gwyddion open source SPM image analysis software. This complete image analysis package has all the software functions necessary to process, analyze and display SPM images.

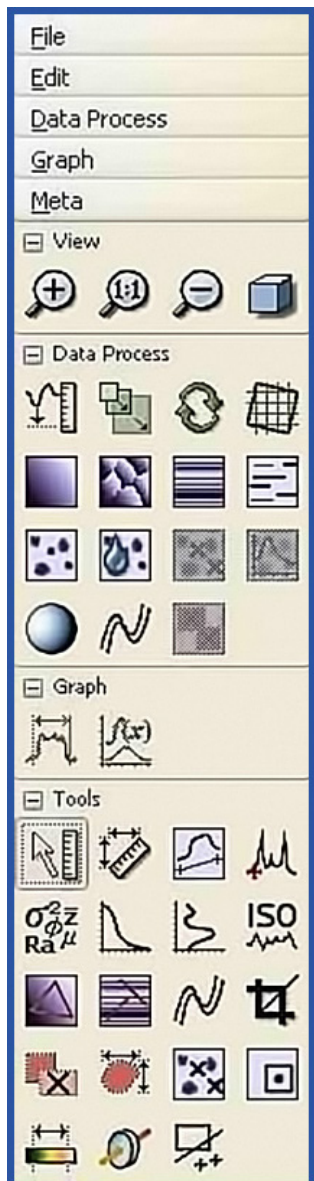

- » visualization: false color representation with different types of mapping
- » shaded, logarithmic, gradient- and edge-detected, local contrast representation, Canny lines
- » OpenGL 3D data display: false color or material representation
- » easily editable color maps and OpenGL materials
- » basic operations: rotation, flipping, inversion, data arithmetic, crop, resampling
- » leveling: plane leveling, profiles leveling, three-point leveling, facet leveling, polynomial background removal, leveling along user-defined lines
- » value reading, distance and angle measurement
- » profiles: profile extraction, measuring distances in profile graph, profile export
- » filtering: mean, median, conservative denoise, Kuwahara, minimum, maximum, checker pattern removal
- » general convolution filter with user-defined kernel
- » statistical functions: Ra, RMS, projected and surface area, inclination, histograms, 1D and 2D correlation functions, PSDf, 1D and 2D angular distributions, Minkowski functionals, facet orientation analysis
- » statistical quantities calculated from area under arbitrary mask
- » row/column statistical quantities plots
- » ISO roughness parameter evaluation
- » grains: threshold marking and un-marking, watershed marking
- » grain statistics: overall and distributions of size, height, area, volume, boundary length, bounding dimensions
- » integral transforms: 2D FFT, 2D continuous wavelet transform (CWT), 2D discrete wavelet transform (DWT), wavelet anisotropy detection
- » fractal dimension analysis
- » data correction: spot remove, outlier marking, scar marking, several line correction methods (median, modus)
- » removal of data under arbitrary mask using Laplace or fractal interpolation
- » automatic xy plane rotation correction
- » arbitrary polynomial deformation on xy plane
- » 1D and 2D FFT filtering
- » fast scan axis drift correction
- » mask editing: adding, removing or intersecting with rectangles and ellipses, inversion, extraction, expansion, shrinking
- » simple graph function fitting, critical dimension determination
- » force-distance curve fitting
- » axes scale calibration
- » merging and immersion of images
- » tip modeling, blind estimation, dilation and erosion

# VIDEO MICROSCOPE

A video optical microscope in an AFM serves three functions: aligning the laser onto the cantilever in the light lever AFM, locating surface features for scanning, and facilitating probe approach. The TT-AFM includes a high performance video optical microscope along with a 3 mega pixel ccd camera, light source, microscope stand, and Windows software for displaying images.

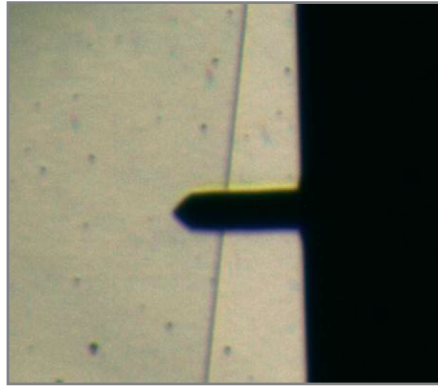

Video microscope used to locate surface features for scanning. The Vibrating Mode Cantilever is 125  $\mu$  long.

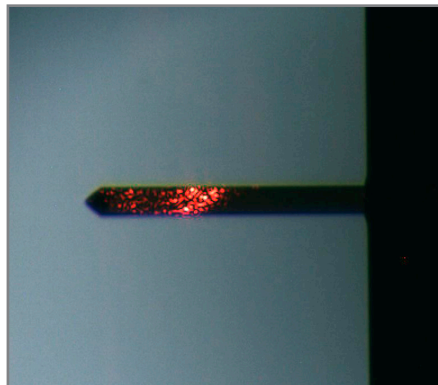

Laser alignment is greatly facilitated with the video optical microscope. This non-vibrating cantilever is 450  $\mu$  long. The red spot is from the laser reflecting off the cantilever.

# PROBE HOLDER/ EXCHANGE

The TT-AFM utilizes a unique probe holder/exchange mechanism. Probes are held in place with a spring device that mates with a probe exchange tool. With the probe exchange tool, changing probes takes only a few minutes.

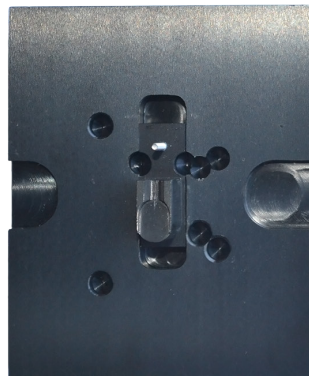

Probe Exchange Tool

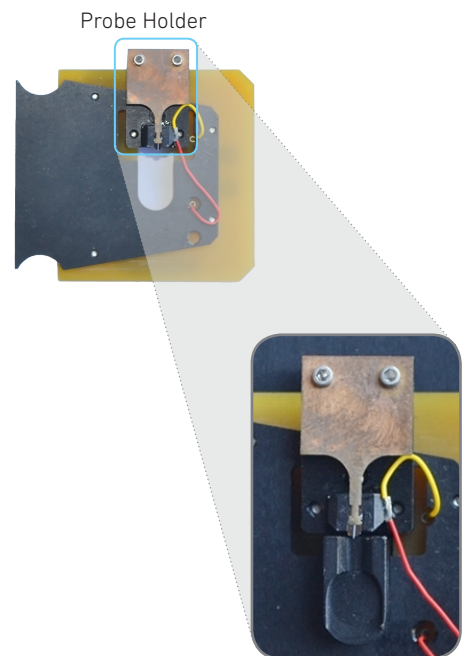

Probe Inserted in Clip

# TT-AFM IMAGES

With a vertical noise floor of 0.1 nm and a horizontal resolution of 2 nm, most types of samples may be imaged with the TT-AFM. These include hard as well as soft samples.

## OPEN DESIGN

An open design is at the core of all products offered by the AFM Workshop. New types of experiments are more readily designed and implemented through the use of LabView software. All the mechanical drawings for the TT-AFM are available in the documentation package option. Finally, the company's website offers a Users Forum to directly share specialized designs developed for the TT-AFM. For specialized applications, other types of scanners such as flexure and tubes can be easily added to the microscope stage.

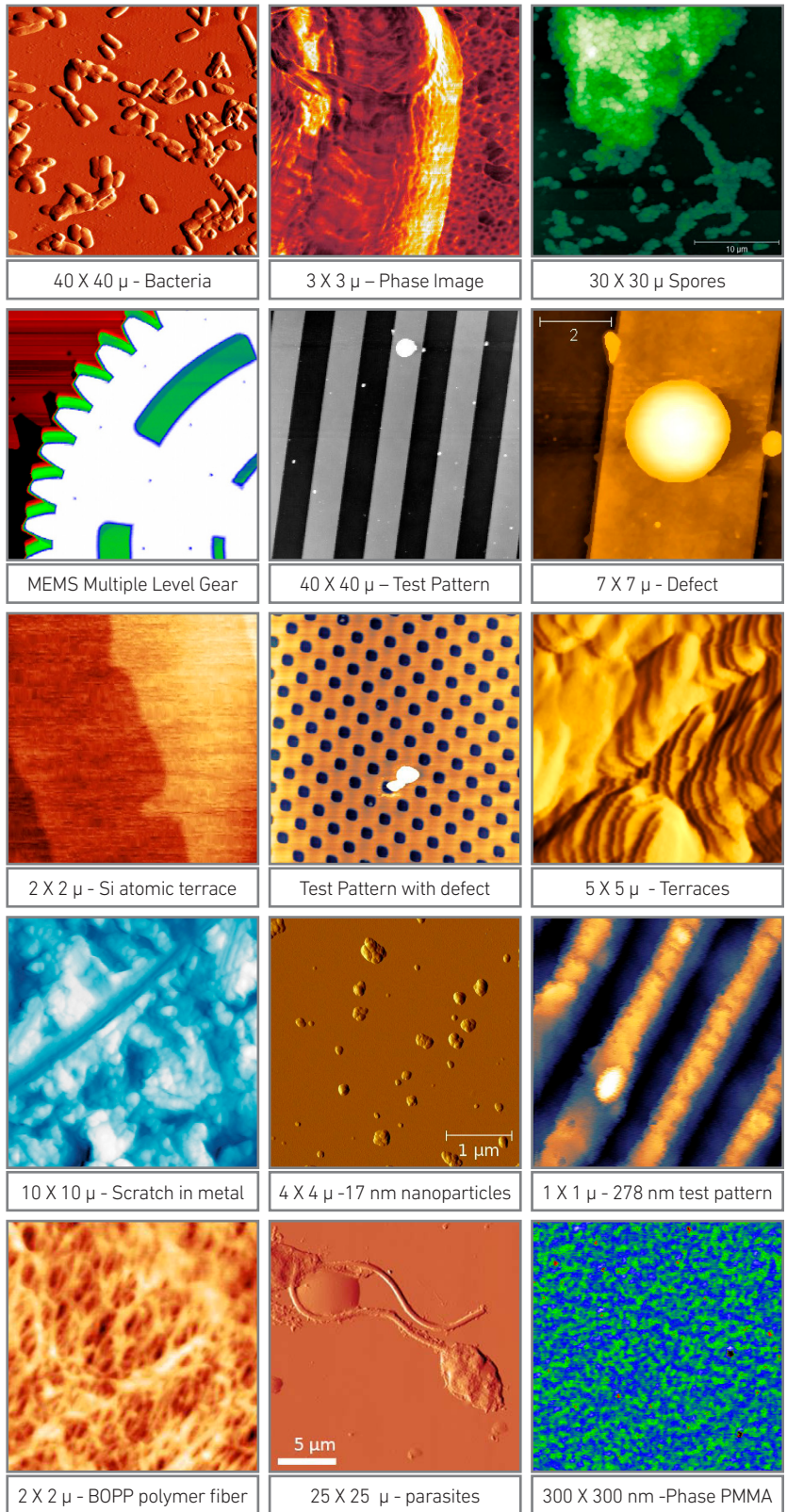

# SCANNING MODES

Standard with every TT-AFM are non-vibrating(NV) mode and vibrating(V) modes for making topography scans. Additional modes included with the product are lateral force imaging as well as phase mode imaging. All of the scanning modes that can be implemented with a light lever AFM are possible with the TT-AFM.

With the window below, the resonance frequency of a cantilever is readily measured. Additionally, the phase characteristics of the probe sample interaction are captured.

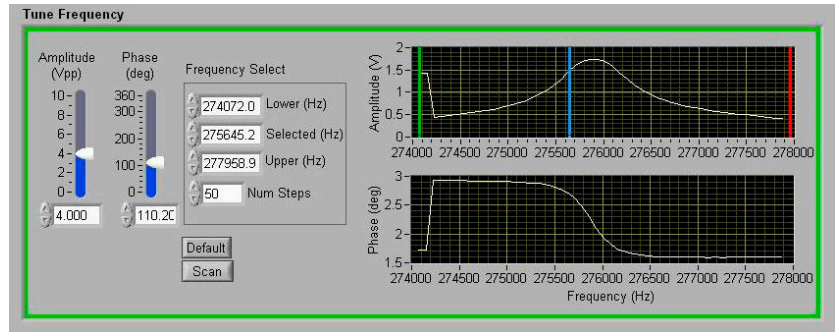

# TT-AFM OPTIONS

Although the TT-AFM comes with everything you need to make AFM images, several options are currently available.

- ▶ **Environmental Cell**  
Permits scanning in inert environments or liquids.
- ▶ **Scanner Fabrication Tool**  
Facilitates scanner fabrication.
- ▶ **High Resolution Scanner**  
Allows a range of 15 X 15 microns in XY and 7 microns in Z.
- ▶ **Vibration Cabinet**  
Reduces unwanted acoustic and structural vibrations.
- ▶ **Conductive AFM**  
Measures the 2-D conductivity of sample surfaces.

AFM Workshop regularly develops new Options.

Contact AFM Workshop for more information on options for the TT-AFM.

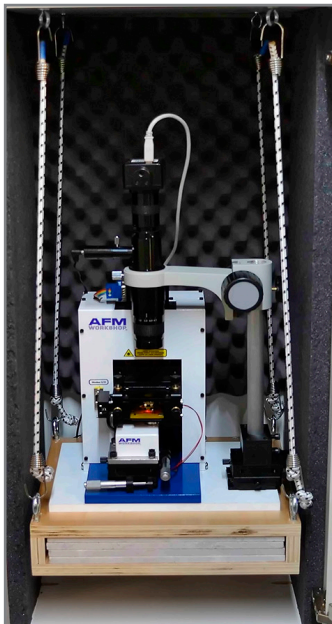

Vibration Enclosure

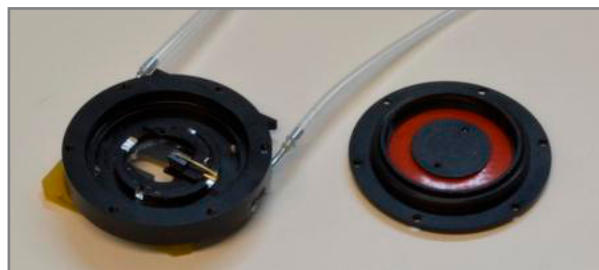

Environmental Cell



15 micron scanner



# SPECIFICATIONS

## ▶ 50 Micron xyz Scanner

» Type	Modified tripod
» XY Linearity	< 1%
» XY Range	> 50 $\mu$
» XY resolution	< 10 nm closed loop < 1 nm open loop
» XY Actuator type	Piezo
» Sensor type	Strain Gauge
» Z Range	> 16 $\mu$
» Z Linearity	< 5 %
» Z sensor noise	< 5 nm
» Z feedback noise	< 0.2 nm*
» Z Actuator Type	Piezo
» Z Sensor type	Strain Gauge

## ▶ 15 Micron xyz Scanner

» Type	Modified tripod
» XY Linearity	< 1%
» XY Range	> 15 $\mu$
» XY resolution	< 3 nm closed loop < 0.3 nm open loop
» XY Actuator type	Piezo
» Sensor type	Strain Gauge
» Z Range	> 7 $\mu$
» Z Linearity	< 5 %
» Z sensor noise	< 5 nm
» Z feedback noise	< 0.1 nm*
» Z Actuator Type	Piezo
» Z Sensor type	None

## ▶ Sample Holder

» Type	Magnet
» Max Lateral Dimensions	1 inch
» Max. Height	0.25 inch

## ▶ Light Lever AFM Force Sensor

» Probe Types	Industry standard
» Probe insertion	Manual – probe exchange tool
» Probe holding mechanism	Clip Vibrating mode piezo Electrical connector to probe
» Laser/Detector adjustment range	+/- 1.5 mm
» Adjustment resolution	1 micron
» Minimum Probe to Objective	25 mm
» Laser Type	670 nm diode, < 5 mw
» Detector	
Type	4 quadrant
Band Width	> 500 kHz
Signals Transmitted	TL, BL, TR, BR
Gain	Lo, High Settings
» Probe sample angle	10 degrees

## ▶ XY Translator

» Range	25.4 mm
» Resolution	2 $\mu$
» Type	Bearing – spring loaded
» Lock Down	Yes

## ▶ Z Motion

» Type	Direct Drive
» Range	25 mm
» Drive Type	Stepper Motor
» Min. Step Size	330 nm
» Slew Rate	8 mm/minute
» Limit Switch	Top, Bottom
» Control	Software – rate, step size

## ▶ Digital Data Input Output

» Connection	USB
» Scanning DAC	
Number	2
Bits	24
Frequency	7 kHz
» Control DAC	
Number	2
Bits	14
Frequency	2 kHz
» ADC	
Number	8
Bits	14
Frequency	48 kHz

## ▶ Analog Electronics

» Vibrating Mode	
Freq Range	2 kHz – 800 kHz
Output Voltage	10 Vpp
Demod. Freq	TBD
» Z Feedback	
Type	PID
Bandwidth	> 3 kHz
Sample Hold	Yes
Voltage	0-150 V
» XY Scan	
Voltage	0 – 150 V
bandwidth	> 200 Hz
Pan & Zoom	22 Bits
» Tip Approach Cutoff	> 20 $\mu$ sec.

# SPECIFICATIONS CONTINUED

## ▶ Software

» Environment	Lab VIEW
» Operating System	Windows 7
» Image Acquisition	Real Time Display (2 of 8 channels)
» Control Parameters	
PID	Yes
Setpoint	Yes
Range	Yes
Scan Rate	Yes
Image Rotate	0 and 90 degrees
» Laser Align	Yes
» Vibrating Freq. Display	Yes
» Force Distance	Yes
» Tip Approach	Yes
» Oscilloscope	Yes
» Image Store Format	Industry Standard
» Image Pixels	16 X 16 to 1024 X 1024
» H.V. Gain Control	XY and Z
» Real time display	Line Level, Light Shaded, Grey Color Pallet System Window
» Calibration	Yes
» Probe Center	Yes

## » Video Microscope

	Minimum Zoom	Maximum Zoom
Field of view	2 X 2 mm	300 X 300 u
Resolution	20 μ	1.5 μ
Working Distance	114 mm	114 mm
Magnification	45 X	400X

» Computer Industry Standard  
Computer

\* Z Noise performance depends greatly on the environment the TT-AFM is used in. Best Z noise performance is obtained in a vibration free environment.

\*\* Every effort is made to present accurate specifications, however, due to circumstances out of the AFMWorkshop's control specifications are subject to change.